



## LSFS-50W-AL

### 50 Watts Floorstanding Loudspeaker



- Extraordinary design
- 2-way-system, 360° reflection technique
- Easy mounting



AUDEMO-SYSTEMS GmbH  
Schatzbogen 62  
81829 München, Germany  
CE-Symbol gemäß Richtlinie 93/68EWG

#### APPLICATION

- Outdoor Background Music

#### AREA OF USE

- Retail • Hospitality
- Theme parks • Gardens

#### OVERVIEW

An extraordinary design and outstanding technical features turn the LSFS-30W-AL into a particularly interesting freestanding loudspeaker.

The 2-way system and hyperbolic 360° distribution ensure the highest sound quality.

The corrosion-free, plastic-coated RAL 9006 white aluminum housing is supplied with a round mounting plate and the speaker comes in structural black as standard.

The LSFS-30W-AL is especially suited for outdoor use in areas like theme parks, playgrounds, promenades, resorts and shopping malls.

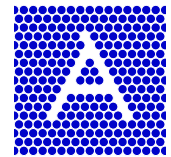

## FREQUENCY RESPONSE DIAGRAM

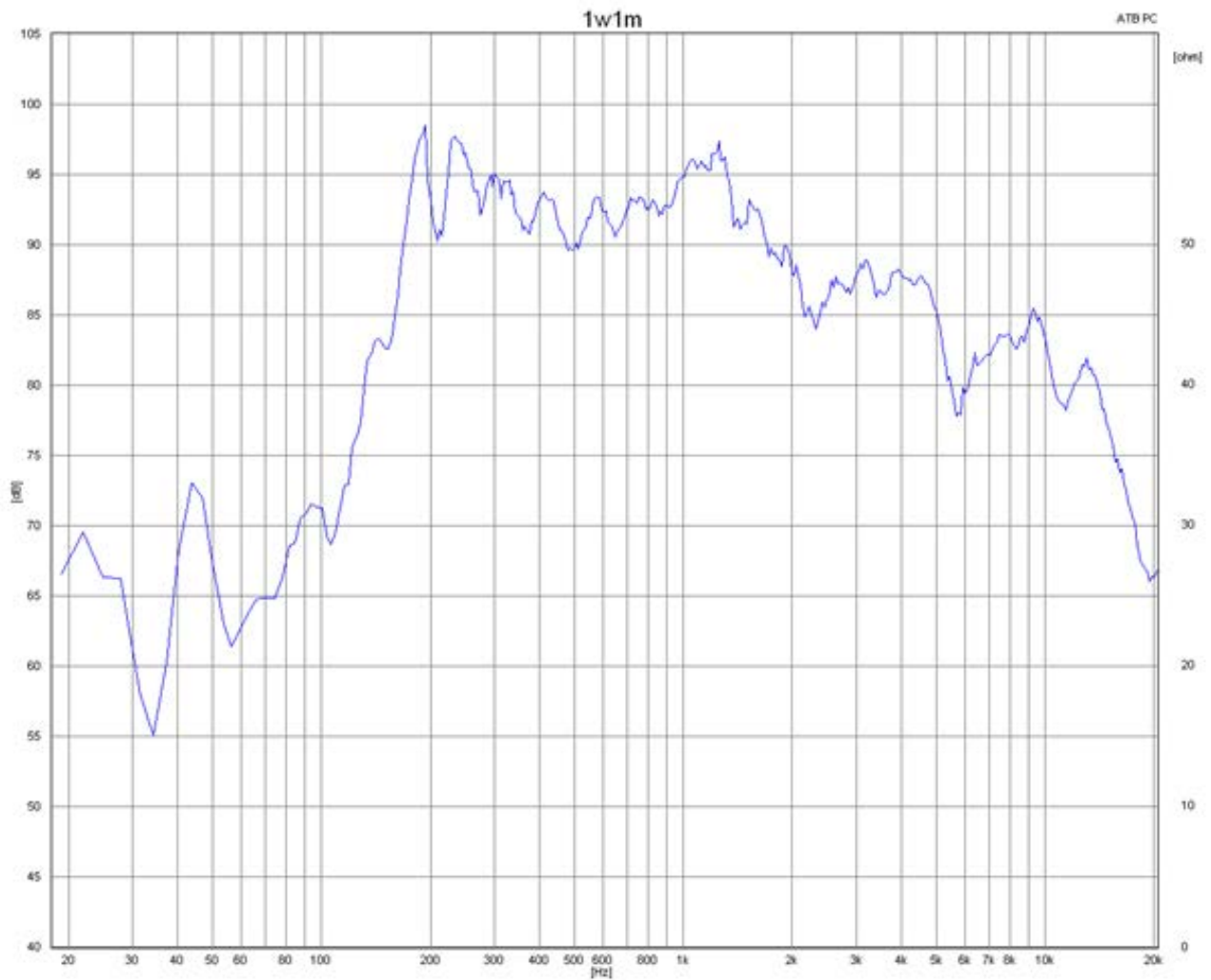



TECHNICAL DIAGRAMS

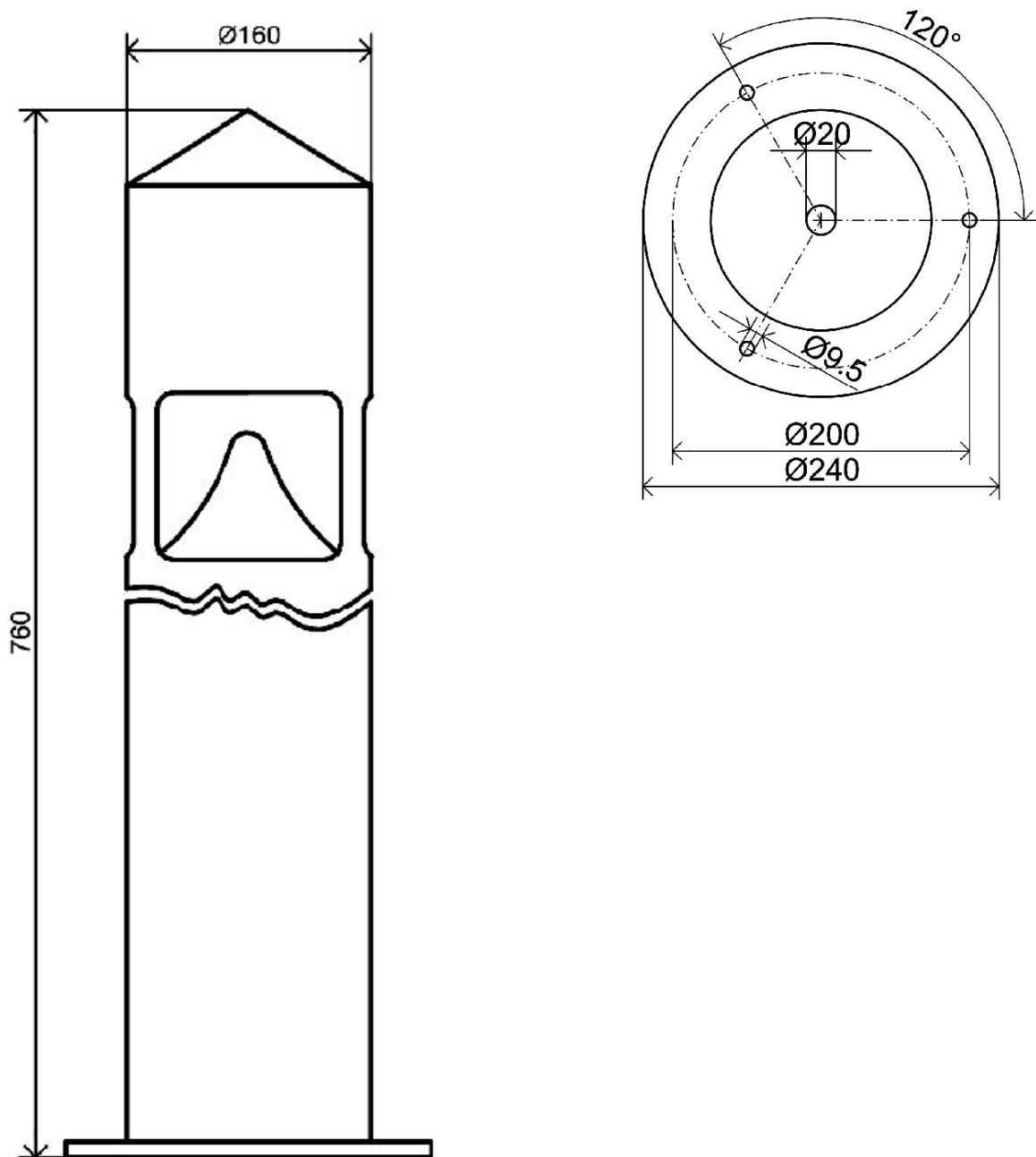

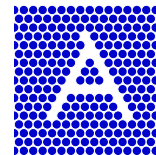

## TECHNICAL DATA (ELECTRICAL)

Description	LSFS-50W-AL
Power	50/25/12,5W
Impedance (100V)	333 / 667 / 1333 ohm
Frequency Range	120 - 16.000 Hz
Sensitivity 1W/1m, IEC 268-5	90.5 dB
Sensitivity Pmax/1m	105,2 dB
Dispersion -6dB, 1KHz	360°
Dispersion -6dB, 4KHz	360°

## TECHNICAL DATA (MECHANICAL)

Dimensions	D240x760 mm
IP Rating	IP66
Weight (net)	9,1 kg
Mounting	Mounting plate
Connector	WAGO connector
Colour	RAL 9006

**All rights reserved.**

Information contained in this document is believed to be accurate, however no representation or warranty is given and Audemo-systems in Germany assumes no liability with respect to the accuracy of such information.



Member of the ZVEI - Central Association  
for the Electrical Engineering and Electrical  
Industry eV Safety Association



**AUDEMO - SYSTEMS GmbH (Headquarter)**

Schatzbogen 62 81829 Munchen  
Tel.: +49 (0) 89 1 4 56 78 47 - 0, Fax: +49 (0) 89 1 4 56 78 47- 2900  
info@audemo-systems.de, www.audemo-systems.de