



LSFS-50W-AL

50 Watts Floorstanding Loudspeaker



- Extraordinary design
- 2-way-system, 360° reflection technique
- Easy mounting



AUDEMO-SYSTEMS GmbH
Schatzbogen 62
81829 München, Germany
CE-Symbol gemäß Richtlinie 93/68EWG

APPLICATION

- Outdoor Background Music

AREA OF USE

- Retail • Hospitality
- Theme parks • Gardens

OVERVIEW

An extraordinary design and outstanding technical features turn the LSFS-30W-AL into a particularly interesting freestanding loudspeaker.

The 2-way system and hyperbolic 360° distribution ensure the highest sound quality.

The corrosion-free, plastic-coated RAL 9006 white aluminum housing is supplied with a round mounting plate and the speaker comes in structural black as standard.

The LSFS-30W-AL is especially suited for outdoor use in areas like theme parks, playgrounds, promenades, resorts and shopping malls.

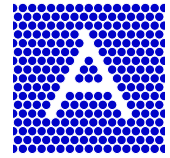

FREQUENCY RESPONSE DIAGRAM

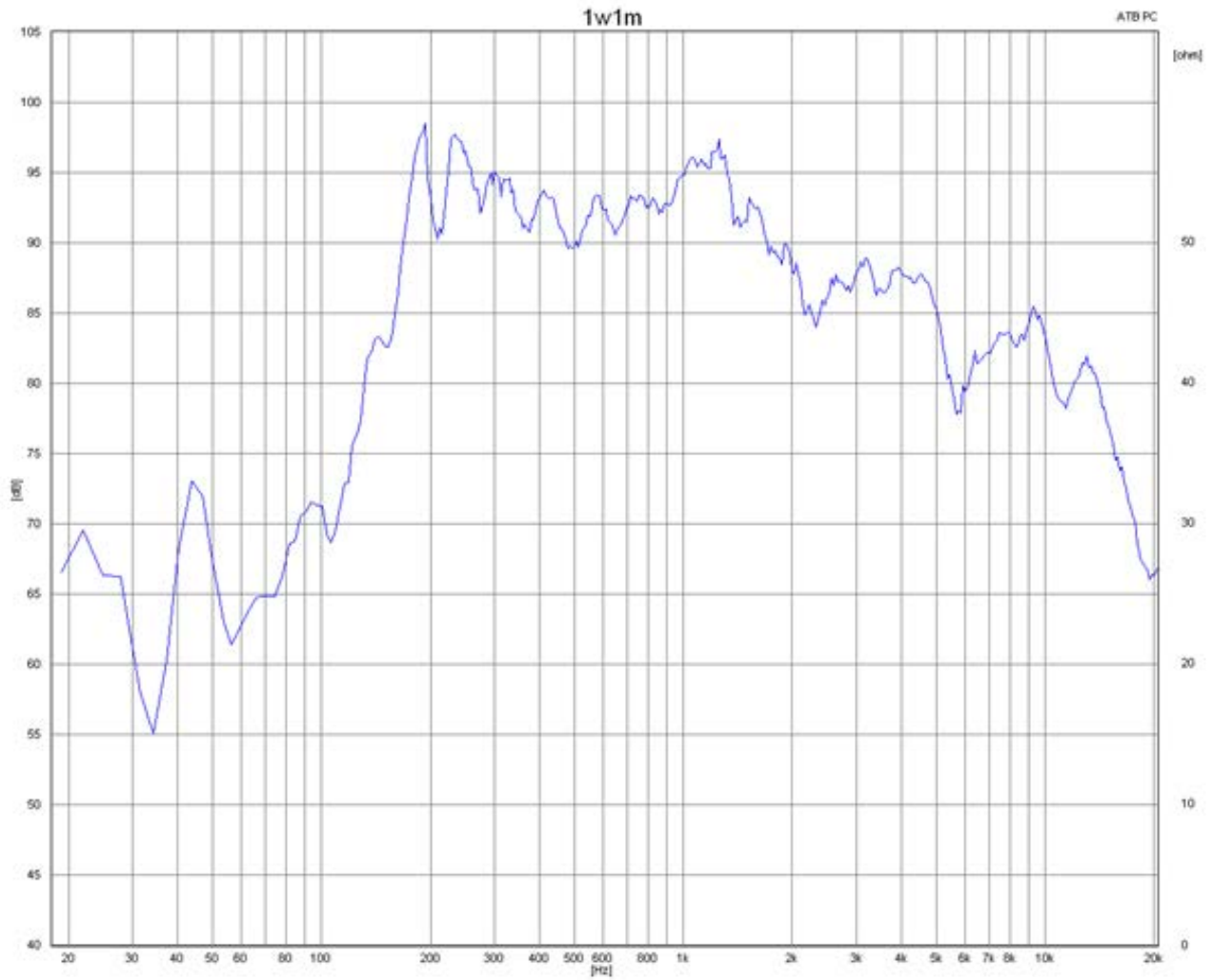



TECHNICAL DIAGRAMS

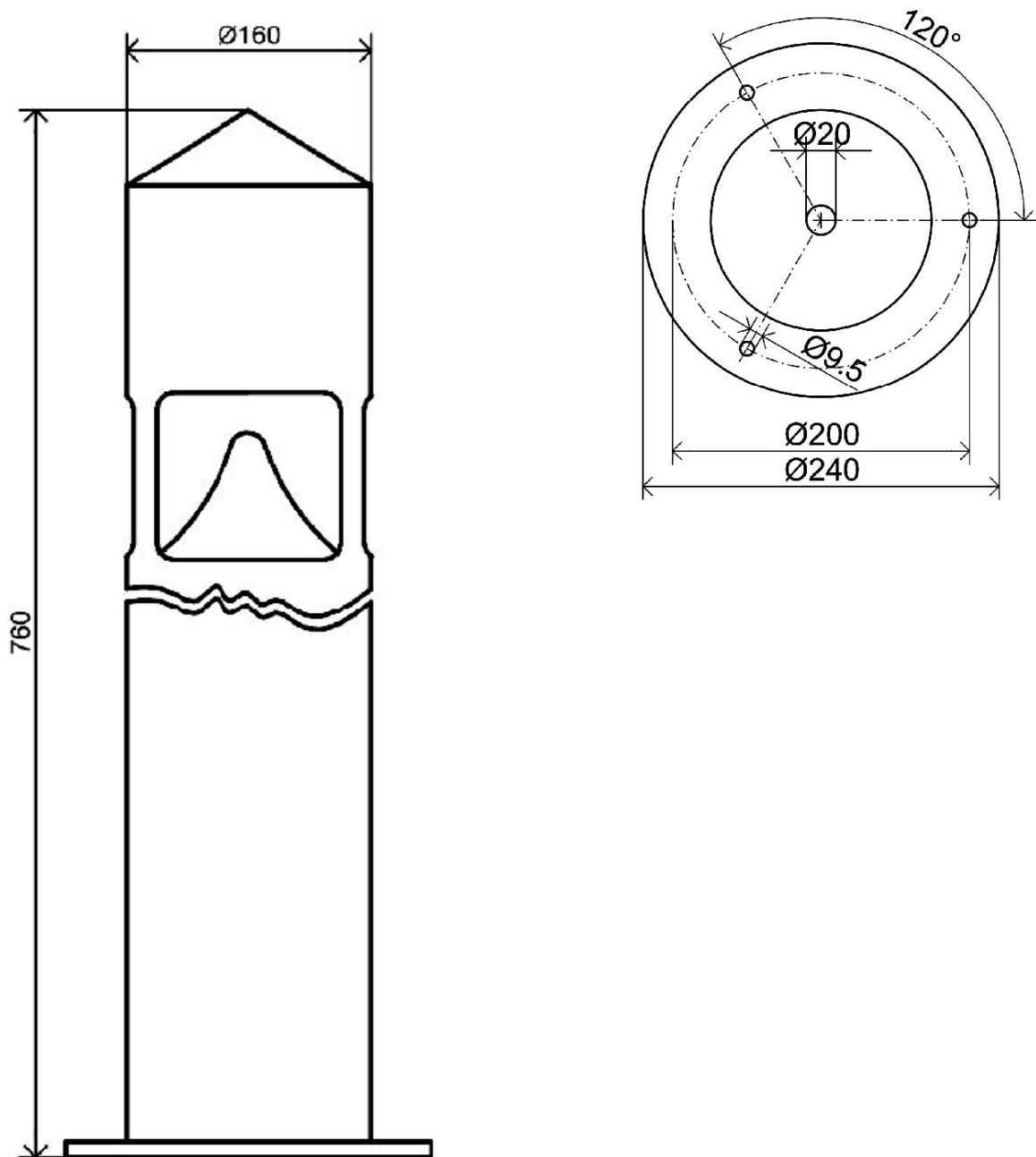

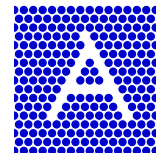

TECHNICAL DATA (ELECTRICAL)

Description	LSFS-50W-AL
Power	50/25/12,5W
Impedance (100V)	333 / 667 / 1333 ohm
Frequency Range	120 - 16.000 Hz
Sensitivity 1W/1m, IEC 268-5	90.5 dB
Sensitivity Pmax/1m	105,2 dB
Dispersion -6dB, 1KHz	360°
Dispersion -6dB, 4KHz	360°

TECHNICAL DATA (MECHANICAL)

Dimensions	D260x760 mm
IP Rating	IP66
Weight (net)	9,1 kg
Mounting	Mounting plate
Connector	WAGO connector
Colour	RAL 9006

All rights reserved.

Information contained in this document is believed to be accurate, however no representation or warranty is given and Audemo-systems in Germany assumes no liability with respect to the accuracy of such information.



Member of the ZVEI - Central Association
for the Electrical Engineering and Electrical
Industry eV Safety Association



AUDEMO - SYSTEMS GmbH (Headquarter)

Schatzbogen 62 81829 München
Tel.: +49 (0) 89 1 4 56 78 47 - 0, Fax: +49 (0) 89 1 4 56 78 47- 2900
info@audemo-systems.de, www.audemo-systems.de