

# User Manual

## DEU-2700 D

### Digital-Emergency-Unit



## Index

1. General .....	3
Symbols and Important Notes.....	3
<b>2. Safety Instructions</b> .....	<b>4</b>
Please Note: .....	5
3. Technical Features .....	6
4. Operational Controls.....	7
Front Panel: .....	7
Rear Panel:.....	8
5. Connections and additional Possibilities .....	9
Connection of the batteries .....	9
6. Options.....	10
7. Specifications .....	11
Digital-Emergency-Unit (DEU-2700 D).....	11
Emergency-Fuse-Expansion-Module (DEU-2766 B) .....	11
Battery-Temperature-Sensor (DEU-2750 A).....	11
<b>HF-Shielding-Module</b> (DEU-2789 A) .....	11
8. Environment Protection .....	12
Note:.....	12
Dispose of this Product.....	12

## 1. General

This operation manual includes important notes on safe operation of the unit. Please read all instructions and safety regulations. Keep these instructions for future reference. Take care that the operation manual is available to all users.



Our products are subject to continuous development. Therefore any technical modification subject to change without notice.

### Symbols and Important Notes

This section provides you with an overview of safety warnings and symbols and their importance.

Safety Warning	Importance
<b>DANGER!</b>	Warning of a possible danger, which can lead to death or to serious injuries, if not avoided.
<b>CAUTION!</b>	Warning of a possible danger, which can lead to a possibly dangerous situation, if not avoided.

Warning Symbol	Type of risk
	Caution! Warning of a possible danger!
	Caution! Risk of electric shock!

## 2. Safety Instructions

1. Please read all instructions before operating the unit.
2. Keep these instructions for future reference.
3. Follow manufacturer's instructions.
4. Pay attention to all warnings. Do not remove any safety instruction or other information from the unit.
5. Use the unit only in the intended way.
6. Take note of applicable safety regulations.
7. **CAUTION!** Select the assembly site in such a way that the unit can be sufficiently cooled. Take care of the details of the brief instructions.
8. **CAUTION!** Do not block vents.
9. **CAUTION!** Keep away flammable materials, liquids and gases.
10. **CAUTION!** Do not use this unit near water or moisture. Take care that no liquid penetrates into the unit.
11. The installation must be carried out only with accessories recommended by AUDEMO SYSTEMS<sup>®</sup>. All options could only be assembled ex works in terms of warranty.
12. **CAUTION!** Do not open or modify the unit.
13. Opening of the security protected unit for servicing, repair and so on is only allowed by the service department of AUDEMO SYSTEMS<sup>®</sup>. Interventions to the unit and breaking the seals will invalidate the warranty agreement!
14. Opening of the unit deactivates all functions! For a reactivating in factory a fee will be charged!
15. **CAUTION!** Always take care about all connections and cables after installation to avoid damages and accidents with e.g. trip hazards.
16. **DANGER!** Pay highest attention while transporting that the system could never drop down or fall over and causes injuries and material damage.
17. **CAUTION!** In any case of acute malfunction of the unit, damage or impact of objects or fluids, switch off the unit immediately and disconnect mains and emergency power supply. The unit as well as the system could only be repaired or changed by the specialized company, the contracted maintenance company or the manufacturer.
18. **CAUTION!** The batteries should only be replaced with batteries of the same version and same capacity. You must change both batteries of one set at the same time and replace it with batteries of the same batch.
19. Clean the surface of the unit with a soft cotton cloth.
20. Pay attention to actual waste disposal laws and regulations.

**Please Note:**



**DANGER!**  
**Risk of electric shock of dangerous voltage within the units enclosure**

Within the units enclosure there are uninsulated parts with height electric tension. Do not remove the cover. There are no user serviceable parts inside.



**DANGER!**  
**Risk of electric shock by short circuit**

Always use properly earthed mains connections. Do not manipulate any cable or cable connector. Noncompliance could lead to electric shock with danger of serious injuries, death and fire! If you are not sure please contact the specialized company, the contracted maintenance company or the manufacturer



**DANGER!**  
**Possible Hearing Damage**

The system produces a volume level which could damage your hearing continuously or temporarily while listening to long to headphone or loud-speaker sound sources.

Do not reproduce high volume levels for a long time. Reduce the level immediately if any noise in ear or hearing loss occurs. Note: The level of the alert announcement may not be changed!



**Caution!**  
**Risk of Fire caused by False Polarity**

Wrong installation of batteries could destroy them!  
Take care of correct polarity while changing or servicing the batteries!

Attention should be paid to the installation instructions of the schematic diagram of the system and the operation manual in case of any servicing or exchange of the batteries. Replace any battery at the end of its lifetime, which means, when the battery storage could only be charged up to 80 percent of its nominal capacity. At least you have to change the batteries after a usage of 4 years. The batteries should only be replaced with batteries of the same version and same capacity. You must change both batteries of one set at the same time and replace it with batteries of the same batch.



**CAUTION!**  
**Operating Conditions**

The unit is intended for indoor use. To prevent damage do not use this unit near liquids and moisture. Avoid direct sunlight, heavy dirt or strong vibration.



**CAUTION!**  
**Power Supply**

Verify the mains connection before installation of the unit. Compare local conditions with the information of the schematic diagram.

Initial operation, maintenance and servicing could only be affected by the specialized company, the contracted maintenance company or the manufacturer.

### 3. Technical Features

The PADES<sup>®</sup>2000 **Digital Emergency Unit DEU-2700 D** enables a standard-compliant (according to EN 54-4), permanent emergency power supply of 24 V DC consumers in the event of a power failure. The 19 inch device (2U) is equipped with a battery extension module and two digital charging modules. Each of the 6 outputs can be loaded with 40 A each and is equipped with a monitored output fuse of a maximum of 40 A. Up to two **battery sets DEU-2771 A** can be connected to the battery extension module and charged, with the total charging current being up to 15 A without constant consumers. Each connected battery set DEU-2771 A supplies three switchable and individually fused consumer outputs with a total nominal current of max. 100 A.

With the **emergency fuse expansion module DEU-2766 B**, it is possible to connect 18 additional power amplifiers (option).

The Digital Emergency Control Module enables the unit to be controlled and monitored. The integrated 32-bit ARM Cortex M3 digital processor (120 MHz) offers sufficient computing power for real-time control of all processes. With the help of the system software license, all processes are controlled and communication with all system components is implemented.

An integrated deep discharge protection for each connected battery set DEU-2771 A, as well as a temperature-controlled end-of-charge voltage (with optional **battery temperature sensor DEU-2750 A**) ensure an optimal service life of the connected batteries. The intelligent condition monitoring of the batteries and chargers ensures safe and uninterrupted operation of the system. The batteries are recharged immediately after the mains supply is restored. The temperature-controlled fan ensures sufficient, demand-controlled cooling of the device.

The LED`s built into the front allow error states to be detected quickly.

The **HF shielding module DEU-2789 A** effectively protects the electronic components against high-frequency electromagnetic radiation by means of system-grounded shielding. Please note: Batteries, battery cable set and battery fuse are not included in the scope of delivery. For warranty reasons, all options can only be installed in the factory. All system components are delivered exclusively project-related. A purchase of individual components is unfortunately not possible.

## 4. Operational Controls

### Front Panel:



**1 BAT (FAIL)**

The LED BATT “FAIL” is illuminated yellow if there is any failure (Battery Fault).

**2 BAT (LOW)**

The LED BATT “LOW” is illuminated yellow if the battery is low. (Charging/Battery).

**3 CTRL (OK)**

The LED CTRL OK is illuminated green if the Controller ist OK.

**4 AC CH (Channel OK)**

The green LED MENUE is illuminated if the AC Channel is OK

**Rear Panel:**

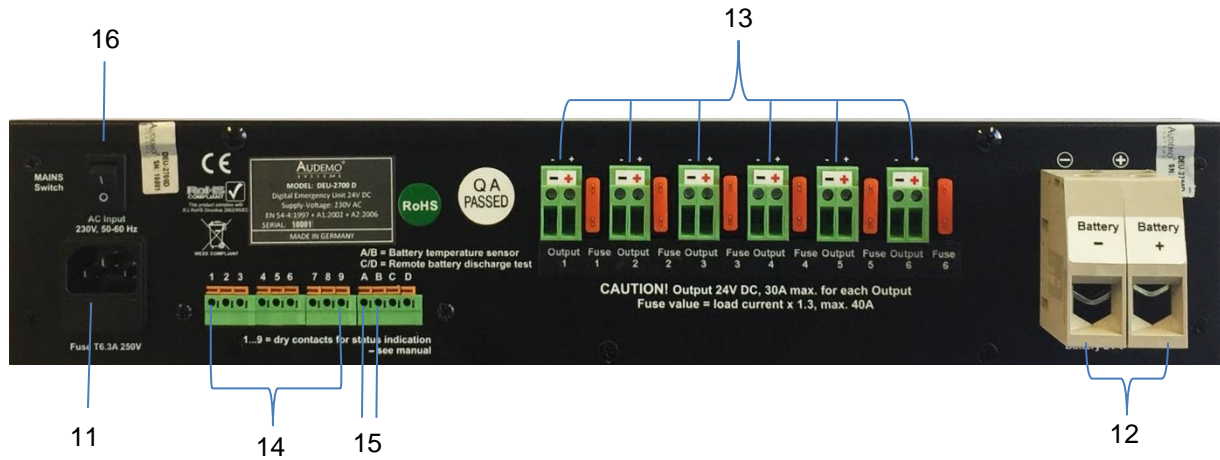

11	<b>Mains Plug Input</b> Power connection to 230 V AC mains. Note the information of the schematic diagram.
12	<b>Connection for Battery-Set</b> To connect up to 2 x DEU-2771 A battery-set 24V/100Ah.
13	<b>Connection Emergency Power for the Amplifier</b> To connect up to 6 amplifiers of the DAA-series.
14	<b>Binding Posts ERROR</b> Fault indication (isolated switchover contact). Bridge from 2 – 4 and 5 – 8
15	<b>Temp.-Sensor</b> Connection of the temperature sensor for thermic control of both battery sets to regulate charging voltage and duration. A = hot, B = cold.
16	<b>Main-Switch</b>



## 5. Connections and additional Possibilities

The Digital-Emergency-unit is equipped individually on consumers request at the factory. Please note all information of the schematic diagram.

### Connection of the batteries

Take care of correct polarity while changing or servicing the batteries!

**DANGER!** Avoid short circuits! Use isolated tools only!

**CAUTION!** The screwing of the cable-connections must be fixed with 0.12 – 0.15 kNm on each screw point. Use a torque wrench!

Attention should be paid to the installation instructions of the schematic diagram of the system and the operation manual in case of any servicing or exchange of the batteries.

Replace any battery at the end of its lifetime, which means, when the battery storage could only be charged up to 80 percent of its nominal capacity. At least you have to change the batteries after a usage of 4 years.

**CAUTION!** The batteries should only be replaced with batteries of the same version and same capacity. You must change both batteries of one set at the same time and replace it with batteries of the same batch.

## 6. Options

Order number	Description	Max. extension per unit
DEU-2700 D	Digital-Emergency-Unit	
DEU-2750 A	Battery-Temperature-Sensor	1x
DEU-2789 A	HF-Shielding-Module	1x
DMS-2098 A	Special-Legend for System	1x
DPU-2686 A	System-Mains-Connecting-Cable	1x

All options could only be assembled ex works. All components of the electroacoustic system could only be delivered referring to a project. Unfortunately there is no possibility of buying single components.

## 7. Specifications

### Digital-Emergency-Unit (DEU-2700 D)

Moduleinbauplätze	1
Energieversorgung	220-240 V AC, 50 Hz
Leistungsaufnahme	max. 350 W
Nennspannung	24 V DC
Ladestrom	15 A
Summen-Eingangsstrom je Battery-Set	100 A max.
Akkukapazität des Lademoduls	max. 200 Ah (2x100Ah)
Ladeschlussspannung	27.3 V typisch bei 20°C
Schaltausgänge	6
Abmessungen (B x H x T)	483 x 88 x 300 mm (2HE)
Gewicht (bei Vollausbau)	5.4 kg
Schutzklasse	IP30

### Emergency-Fuse-Expansion-Module (DEU-2766 B)

Schaltausgänge	18
Ausgangsstrom je Schaltausgang	20 A max.
Leistungsabgabe des Lademoduls	max. 300 W
Abmessungen (B x H x T)	160x 50 x 30 mm
Gewicht	0,35 kg

### Battery-Temperature-Sensor (DEU-2750 A)

Fühlerspitze	-50 °C bis +105 °C
Schutzklasse	IP54
Kabellänge	4 m
Abmessungen (L x D)	50 x 6 mm
Gewicht	67 g

### HF-Shielding-Module (DEU-2789 A)

Abmessungen (B x H x T)	43 x 34 x 1 mm
Gewicht	10 g

## 8. Environment Protection

### Note:



In any case of replacement, the substituted unit is taken back from the manufacturer.

### Dispose of Batteries



The batteries should not be thrown away or been burned under no circumstances! They must be disposed according to local rules about special waste. Please use the possibilities of your next recycling facility.

### Dispose of this Product



This product is subjected to European directive 2002/96/EG and 2012/19/EU (WEEE-directive). Dispose this product never with your domestic waste.

Dispose a control center system with an accredited waste disposal company or your local disposal facility. Take care of applicable regulations. In case of doubt please contact your local disposal facility.